

HYGIENIC WALL CLADDING

KömaDur® cladding

The KömaDur rigid PVC sheets meet a wide range of requirements and are therefore interesting for a variety of uses and application areas.

KömaDur cladding sheets are particularly hygienic and resistant, and are also easy to clean. They are ideal as wall cladding for interiors, such as kitchens, bathrooms, hospitals, nursing homes and much more.

The sheets with an embossed surface are also even more robust.

#KömmerlingForTomorrow

DELIVERY PROGRAMME

KömaDur embossed

- > 3050 x 1220 x 2.5 mm
- > Colour: White 654
- > Mat. no. 781534

KömaDur matt

- > 2800 x 1220 x 2.5 mm
- > Colour: 654 White
- > Mat. no. 499836

PRODUCT ADVANTAGES

- > Matt or embossed surface
- > Excellent bonding
- > Chemical-resistant
- > Easy to clean
- > Shockproof
- > Easy to install
- > Moisture-resistant
- > Hygienic

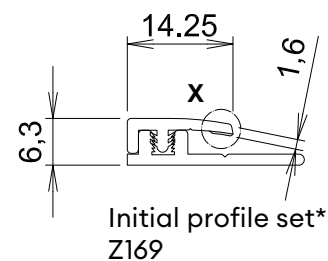
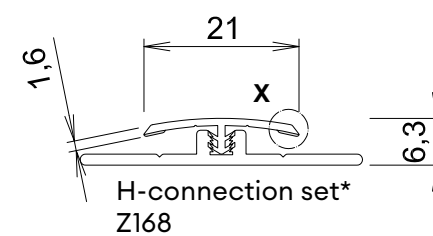
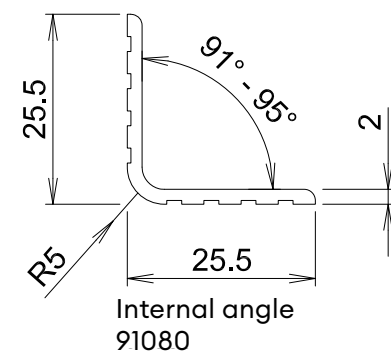
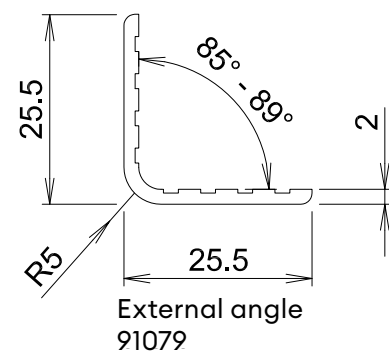

Detail X

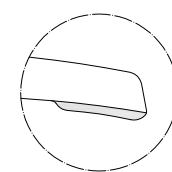

Sealing lip

profine GmbH
Kömmerling

Zweibrücker Straße 200
66954 Pirmasens
Germany
Tel. +49 (0) 6331 560
E-mail: info@koemmerling.com

www.koemmerling.com

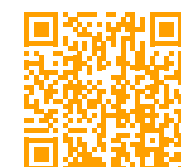

Specifications subject to modification without prior notice. 0924



Kömmerling®
TODAY FOR TOMORROW

HYGIENIC WALL CLADDING

KömaDur® Cladding

CHEMICAL RESISTANCE

Medium	Concentr.	Temperature	
		20 °C	60 °C
Organic chemicals			
Formic acid	10	++	++
Formic acid	100	++	+
Anillin	-	-	-
Ethanol	-	++	+
Petrol-benzene mixture (BV-Aral)	-	-	-
Benzene	-	-	-
Butanol	-	++	++
Cyclohexane	-	++	+
Cyclohexanol	-	++	++
Dekalin	-	++	++
Diesel fuel	-	++	-
Diethyl ether	-	-	-
Glacial acetic acid	-	++	-
Acetic acid	10	++	++
Formalin	-	++	+
Glycol	-	++	++
Fuel oil	-	++	N/A
Heptane	-	++	-
Hexane	-	++	++
m-Cresol	-	+	-
White spirit	-	++	0
Machine oil	-	++	++
Methanol	-	++	+
Olive oil	-	++	++
Petroleum ether	-	++	+
Turpentine oil	-	++	0
Toluene	-	-	-
Transformer oil	-	++	++
Xylene	-	-	-



Medium	Concentr.	Temperature	
		20 °C	60 °C
Inorganic chemicals			
Ammonia	24	++	-
Chromosulphuric acid	-	++	0
Lime potash	10	++	++
Aqua regia	-	++	+
Sodium chlorite	40	++	++
Sodium hydrosulphite	10	++	++
Sodium hypochlorite	40	++	++
Soda lye	10	++	++
Soda lye	40	++	++
Phosphoric acid	10	++	++
Phosphoric acid	85	++	++
Nitric acid	10	++	++
Hydrochloric acid	10	++	++
Hydrochloric acid	35	++	++
Sulphuric acid	10	++	++
Sulphuric acid	96	++	++

++ Good resistance Weight diff. less than 1%
 + Resistant Weight diff. 1 to 5%
 ○ Partially resistant Weight diff. 5 to 10%
 - Not resistant

Other chemicals on request.

SPECIFICATIONS

Mechanical properties	Standard	Unit	
			WA/WA-M
Apparent density*	DIN EN ISO 1183	g/cm ³	- 1.43
Yield stress (tensile strength)	DIN EN ISO 527	MPa	≥ 55
Elongation at break	DIN EN ISO 527	%	≥ 15
Flexural strength	DIN EN ISO 178	MPa	≥ 80
Compressive strength	DIN EN ISO 844	MPa	≥ 70
Modulus of elasticity	DIN EN ISO 527-2 / 1A / 50	MPa	≥ 3000
Notch toughness	DIN EN ISO 179-lePA	kJ/m ²	≥ 4
Impact toughness	DIN EN ISO 179	kJ/m ²	
	0 °C		Without rupture
	-20 °C		-
	-30 °C		-
	-40 °C		-
Ball hardness (358 N/30 s)	DIN EN ISO 2039	MPa	- 100

Thermal properties	Standard	Unit	
			WA/WA-M
Vicat softening temperature	DIN EN ISO 306 (method B50)	°C	≥ 75
Heat distortion temperature	DIN EN ISO 75	°C	- 68
Coefficient of linear expansion - 30 °C to + 50 °C	DIN EN ISO 11359-2 (Ae process)	mm/mK	0.08
Thermal conductivity range from 0 °C to + 60 °C	DIN EN ISO 22007	W/mK	0.16



Electrical properties	Standard	Unit	KömaDur value:
			WA/WA-M
Dielectric constant E _r (at 1 kHz)	VDE 0303 T4	-	3.4
Dielectric loss factor tan δ (at 1 kHz)	VDE 0303 T4	-	0.016
Surface resistance	DIN VDE 0303 T30 DIN IEC 93	Ω	> 10 ¹⁵
Volume resistivity	DIN VDE 0303 T30 DIN IEC 93	Ω · m	> 10 ¹⁴
Dielectric strength	DIN VDE 0303 T21 1 mm plate	kV/mm	≥ 23
Tracking	DIN IEC 112	Level	CTI 600
Arc resistance	DIN VDE 0303 T5	Characteristic value	2.2.2.2

Other properties	Standard	Unit	KömaDur value:
			WA/WA-M
Water absorption after 7 days	DIN EN ISO 62	%	< 0.08
Fire behaviour	DIN EN 13501-1 (EU)	C-s3d0	2.5 mm (white)
	NF P 92-501 (FR)	M1	1-3 mm (WA 640)
	UL 94 (USA)	V0/5VB	1-5 mm (WA white)
	BSE 476 : Part 7 (GB)	Class 1	1.8 mm (WA 646, 640, 654) 2.5 mm (WA 640, 654)
Physiological assessment			Acceptable

*These values are recommended values for the average apparent density.

AREAS OF APPLICATION

Wall cladding, e.g. laundries, hospitals and care facilities, cold stores, large kitchens and canteens, bathrooms, air-conditioning and ventilation elements, cladding and panelling, chemical and laboratory technology.